

April 10, 2015



Danny Lee
Director, Madison County Building and Grounds
Madison County Mississippi
125 West North Street
Canton, Mississippi 39046

RE: Selective Interior Demolition and Renovation for:
Madison County Circuit Courthouse

Mr. Lee,

Regarding the above referenced project, attached, please find the following:

- 3 Originals: Application and Certificate for Payment No. 7
- 3 Original: G701 Change Order
- 3 Original: G704 Certificate of Substantial Completion

We have reviewed the Application for Payment and found it in accordance with our field assessments. Therefore, we recommend payment be remitted to Tyler Construction Group Inc. in the amount of One Hundred Forty Four Thousand, Two Hundred Seventy Dollars and 00/100 (\$144,270.00).

As of this payment application, the project contract amount will be paid in full. This is the final payment application you will receive for the project.

Also attached with this letter you will find 3 copies of the G701 Change Order for the project. This change order is a no cost change order with a time extension approval for the project. The change order tracks and documents all changes, and revisions to the contract scope of work and contract period for the project. I have reviewed the document and find it to be correct as per our previous agreements with the Contractor.

Also attached you will find 3 copies of the G704 Certificate of Substantial Completion. This document certifies that our firm has visited the site and inspected all work for compliance with the contract documents. The document also established the start date of September 4, 2014 for all warranty items on the project.

You will need to have the Board president sign all three copies of the G701 and the G704 for the records. Once all three copies of both documents have been signed, you will keep one copy of each for your records and return the other two copies of each to our office. We will then distribute to the contract their copy and retain one for our records.

Feel free to contact our office if we may be of any assistance.

Respectfully,

Preston L. McKay
Project Manager
M3A Architecture PLLC/
William L. McElroy AIA, NCARB

Attachment

AIA[®] Document G704[™] – 2000

Certificate of Substantial Completion

PROJECT:
(Name and address)
10-018_Madison County Circuit
Courthouse
Madison County Circuit
Courthouse
128 West North Street
Canton, Mississippi

PROJECT NUMBER: 10-018/
CONTRACT FOR: General Construction
CONTRACT DATE: January 9, 2014

OWNER:
ARCHITECT:
CONTRACTOR:
FIELD:
OTHER:

TO OWNER:
(Name and address)
Madison County, Mississippi
146 West Center Street
Canton, Mississippi 39046

TO CONTRACTOR:
(Name and address)
Tyler Construction Group
203 West Beacon Street
Philadelphia, Mississippi 39350

PROJECT OR PORTION OF THE PROJECT DESIGNATED FOR PARTIAL OCCUPANCY OR USE SHALL INCLUDE:

As of the date of final inspection September 4, 2014, all areas of the project are deemed complete and approved for occupancy with the exception of the following:

1. Holding Room 155 - Pending Installation of Wood Door and Hardware due to be completed with Access Control Scope of work.
2. Access Control Scope of Work - Pending installation of all access control hardware, controls, doors and system components, final tie in and punch list for all areas affected by installation.

The Work performed under this Contract has been reviewed and found, to the Architect's best knowledge, information and belief, to be substantially complete. Substantial Completion is the stage in the progress of the Work when the Work or designated portion is sufficiently complete in accordance with the Contract Documents so that the Owner can occupy or utilize the Work for its intended use. The date of Substantial Completion of the Project or portion designated above is the date of issuance established by this Certificate, which is also the date of commencement of applicable warranties required by the Contract Documents, except as stated below:

Warranty

One Year General Contractors Warranty

Date of Commencement

September 4, 2014

M3A Architecture, PLLC

ARCHITECT

BY 

September 4, 2014

DATE OF ISSUANCE

A list of items to be completed or corrected is attached hereto. The failure to include any items on such list does not alter the responsibility of the Contractor to complete all Work in accordance with the Contract Documents. Unless otherwise agreed to in writing, the date of commencement of warranties for items on the attached list will be the date of issuance of the final Certificate of Payment or the date of final payment.

Cost estimate of Work that is incomplete or defective: \$2,500.00

The Contractor will complete or correct the Work on the list of items attached hereto within Thirty (30) days from the above date of Substantial Completion.

Tyler Construction Group

CONTRACTOR

BY 

DATE 9/4/14

AIA Document G704[™] – 2000. Copyright © 1963, 1978, 1992 and 2000 by The American Institute of Architects. All rights reserved. **WARNING: This AIA[®] Document is protected by U.S. Copyright Law and International Treaties. Unauthorized reproduction or distribution of this AIA[®] Document, or any portion of it, may result in severe civil and criminal penalties, and will be prosecuted to the maximum extent possible under the law.** This document was produced by AIA software at 09:04:42 on 01/23/2015 under Order No.3317776989_1 which expires on 12/01/2015, and is not for resale.

User Notes:

(1631875941)

The Owner accepts the Work or designated portion as substantially complete and will assume full possession at _____ (time) on _____ (date).

Madison County, Mississippi

OWNER

BY

DATE

The responsibilities of the Owner and Contractor for security, maintenance, heat, utilities, damage to the Work and insurance shall be as follows:

(Note: Owner's and Contractor's legal and insurance counsel should determine and review insurance requirements and coverage.)

Owner assumes full responsibility for all security, utilities, insurance, maintenance and damage to the building as of September 4, 2014.



AIA[®] Document G701[™] – 2001

Change Order

PROJECT (Name and address):	CHANGE ORDER NUMBER: 001	OWNER: <input checked="" type="checkbox"/>
10-018_Madison County Circuit Courthouse Madison County Circuit Courthouse 128 West North Street Canton, Mississippi	DATE: 7/29/2014	ARCHITECT: <input checked="" type="checkbox"/>
TO CONTRACTOR (Name and address):	ARCHITECT'S PROJECT NUMBER: 10-018	CONTRACTOR: <input checked="" type="checkbox"/>
Tyler Construction Group 203 West Beacon Street Philadelphia, Mississippi 39350	CONTRACT DATE: 1/9/2014	FIELD: <input type="checkbox"/>
	CONTRACT FOR: General Construction	OTHER: <input type="checkbox"/>

THE CONTRACT IS CHANGED AS FOLLOWS:

(Include, where applicable, any undisputed amount attributable to previously executed Construction Change Directives)

Changes Order Additions

1. Additional Concrete	\$19,999.00
2. Window Repair	\$ 5,045.00
3. District Attorney's Office Revision	\$ 1,120.00
4. Sally Port Revision	\$17,108.00
5. Conduit & Wiring Change	\$4,072.00
6. Receptacle Repair	\$2,875.00

TOTAL ADDITIONS \$50,219.00

Change Order Deductions

1. Fire Reiser Deductions	\$ 6,900.00
2. Access Control Deductions	\$ 10,340.00
3. Acrylic to Wood Door Change	\$ 10,578.00
4. Time Extension Credit	\$13,401.00

TOTAL DEDUCTIONS ~~\$47,219.00~~ *use*

Allowance Adjustments

1. Allowance #1: Gypsum Board Repair	\$10,000.00 Credit
2. Allowance #2: Interior Painting	\$ 6,500.00 Credit
3. Allowance #3: Audio Equipment	\$ 0.00 Remaining

TOTAL ALLOWANCE CREDIT \$ 16,500.00

EXTENDED GENERAL CONDITIONS \$ 7,500.00

The original Contract Sum was	\$	800,000.00
The net change by previously authorized Change Orders	\$	0.00
The Contract Sum prior to this Change Order was	\$	800,000.00
The Contract Sum will be unchanged by this Change Order in the amount of	\$	0.00
The new Contract Sum including this Change Order will be	\$	800,000.00

The Contract Time will be increased by Eighty Seven (87) days.

The date of Substantial Completion as of the date of this Change Order therefore is September 4, 2014

NOTE: This Change Order does not include changes in the Contract Sum, Contract Time or Guaranteed Maximum Price which have been authorized by Construction Change Directive until the cost and time have been agreed upon by both the Owner and Contractor, in which case a Change Order is executed to supersede the Construction Change Directive.

NOT VALID UNTIL SIGNED BY THE ARCHITECT, CONTRACTOR AND OWNER.

M3A Architecture, PLLC
ARCHITECT (Firm name)
4880 McWillie Circle, Jackson, MS 39206
ADDRESS
BY (Signature)
William L. McElroy
(Typed name)
1/23/2015
DATE

Tyler Construction Group
CONTRACTOR (Firm name)
203 West Beacon Street, Philadelphia,
Mississippi 39350
ADDRESS
BY (Signature)
Josh Gamblin
(Typed name)
1/23/15
DATE

Madison County, Mississippi
OWNER (Firm name)
146 West Center Street, Canton,
Mississippi 39046
ADDRESS
BY (Signature)
Karl Banks
(Typed name)
DATE



Madison County Buildings and Grounds

Mark Houston, County Administrator • Danny Lee, Director of Buildings & Grounds

125 West North Street, Post Office Box 608, Canton, Mississippi 39046
Office 601-855-5500 • Facsimile 601-855-5759
danny.lee@madison-co.com

MEMORANDUM

APPROVED
BY MADISON COUNTY
BOARD OF SUPERVISORS

Date 4/21/14

Cynthia Parker, Chancery Clerk

By C Parker P.C.

TO: Mark Houston, County Administrator
FROM: Danny Lee, Building and Grounds DL
DATE: April 21, 2014
RE: Circuit Courthouse Renovation, Change Order Request

Per my request, Tyler Construction Group has submitted prices to provide the following changes:

- Additional Concrete Demo and Replacement at Main Entrance \$19,999.00 (Add)
- Correcting additional issues with windows that are contributing to the leaks \$5,045.00 (Add)
- Request for additional days: Twenty-one (21)

Attached are the supporting documents provided by Tyler Construction. If you are in agreement with this request, please have it add to the April 21st Board Agenda.



203 W. BEACON STREET
PHILADELPHIA, MS 39350
601.656.3200 (o)
601.656.3322 (f)
www.tylerconstruct.com

Request for Approval
DL 4/21/2014

To: M3A Architecture
c/o Preston McKay
4880 McWilley
Jackson, Mississippi 39206

From: Tyler Construction Group
Pete Willis
203 W Beacon Street
Philadelphia, MS 39350

RE: Miscellaneous Pricing Requested at Our Last Meeting
Madison Courthouse Selective Interior Demolition & Renovation #10-018

Preston- Below is the pricing and the items we need discussed in the past meeting.

Pricing

1) Additional Concrete Demo and Put Back at Entry

a.	3500sf Concrete Form/Finish-	\$7,875.00
b.	3500sf Wire Mesh-	\$910.00
c.	51cy of Concrete	\$5,406.00
d.	16 Hr Equipment Usage	\$2,000.00
e.	2dy Trucking	\$1,200.00
f.	<u>Sub Total</u>	<u>\$17,391.00</u>
g.	O&P	\$2,608.00
h.	Total for Add	\$19,999.00

2) Add for pulling and resetting windows in Grand Jury Room, reset windows (2) and add breakmetal on top of windows on west wall, replace 3 window panes (54"x76") on east wall

a.	See SubK Quote	\$4,587.00
b.	O&P	\$458.00
c.	Total for Add	\$5,045.00

** To whom it may concern,

This proposal is for change order on the Madison Co. Courthouse project. The second story windows on the east wall look to have been caulked improperly. We propose to remove and reinstall windows properly. Reinstalling the windows properly may or may not solve the problem because of any underlying issues that can't be foreseen. This proposal is our recommendation to attempt to correct the leaking, however because of circumstances that exist GlassWorx cannot provide a warranty.

Thanks for your consideration,
Josh Baysinger

3) Credit for changing Acrylic doors to Wood doors
Total

~~-\$10,578.00~~

OMIT CREDIT

DU

Other Items

Request for additional time – 21 days

I know we talked about all these items in the meeting but I wanted to get them on paper. I'm concerned about the contractual time line and that these items have been dragging on for so long. If we do not get the carpet situation and the access controls clarified ASAP there will be no way possible for us to hit our target dates. We desperately want to start on the footings for the sallyport canopy, but the gas line still has not been addressed. Where the job is at this point we cannot start anything on the site and it's getting me concerned.

Thanks

Pete Willis
Tyler Construction Group
601-656-3200
pw@tylerconstruct.com

GlassWorx

1163 Weyerhaeuser Street
Philadelphia, MS 39350

Phone: 601-389-2020
Fax: 601-389-0331

CHANGE ORDER PROPOSAL

1-2-13

TO: Tyler Group

JOB: Madison Co. Courthouse

ATTN: Pete

WE PROPOSE TO FURNISH AND INSTALL THE FOLLOWING AS REQUIRED:

3- EACH 54" x 76" grey over clear insulated unit on west wall second floor

ALL FOR THE SUM OF-----\$ 2,242.00

2- EACH reset insulated units that have shifted

ALL FOR THE SUM OF-----\$200.00

Breakmetal for top of west wall windows

ALL FOR THE SUM OF-----\$225.00

Windows on east wall that are leaking to be pulled and reinstalled per manufacture specifications (see attached drawing)

ALL FOR THE SUM OF-----\$1,920.00

EXCLUSIONS: TAX, WORK TO ADJACENT CONDITION, OPENING PREPARATIONS, AND/OR FINAL CLEANING.

PROPOSAL VALID FOR 30 DAYS.

APPROVED BY: _____

THANKS,

Josh Baysinger

DATE: _____

SERIES 3000 THERMAL MULTIPLANE INSTALLATION MANUAL

INSTALLATION FOR THERMAL PERFORMANCE

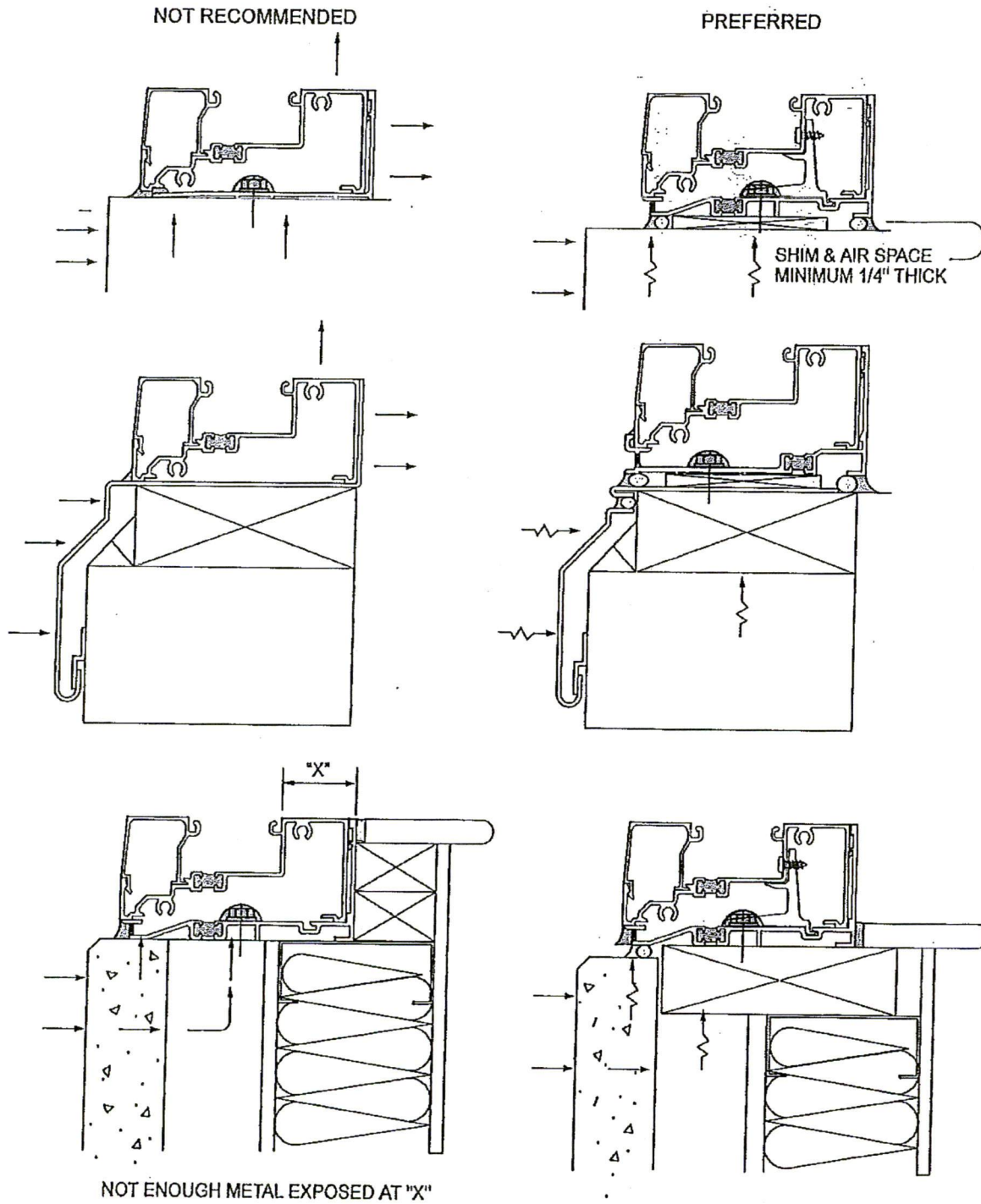

TO DERIVE THE GREATEST BENEFIT FROM YOUR STOREFRONT INSTALLATION,
WE RECOMMEND YOU REVIEW THE DETAILS ABOVE.

SERIES 3000 THERMAL MULTIPLANE INSTALLATION MANUAL

INSTALLATION INSTRUCTIONS FOR FG-3223 SUB-SILL

INSTALL SUB-SILL AND END DAM

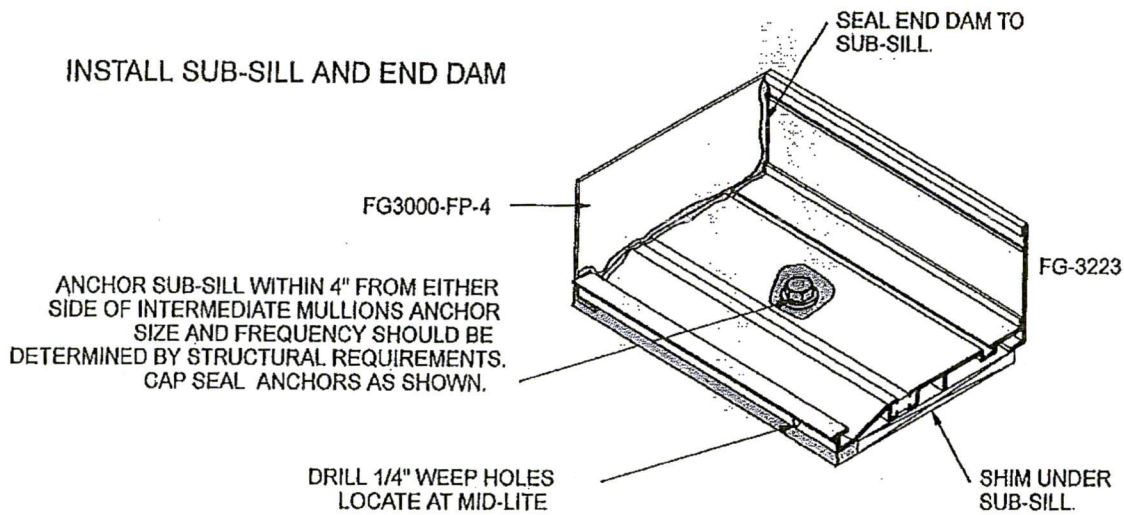

INSTALL SPLICE SLEEVE

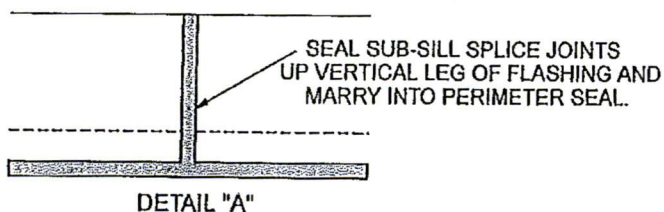
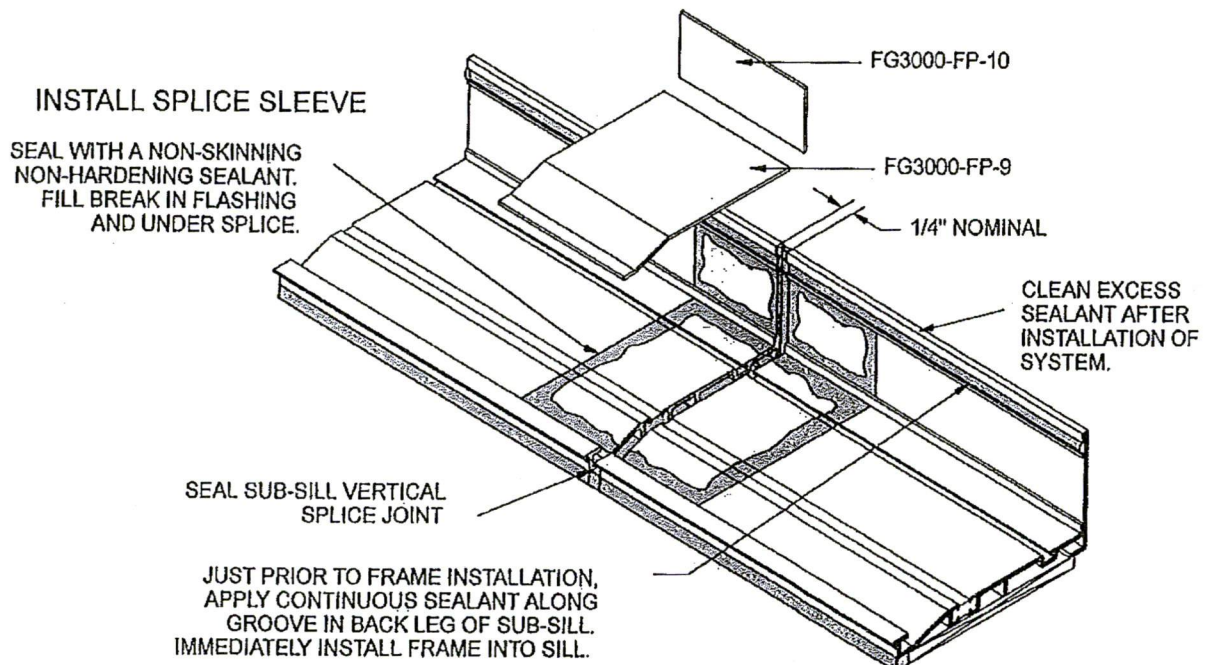

NOTE:

- 1) SUB-SILL SHALL BE INSTALLED LEVEL AND SHOULD NEVER TILT TOWARDS INTERIOR OF BUILDING.
- 2) REFERENCE PAGE 43 FOR END REACTIONS FOR SPECIFIC SILL ANCHORS.
- 3) SPLICE SUB-SILL AT MID-LITE ON LONG RUNS.

SERIES 3000 THERMAL MULTIPLANE INSTALLATION MANUAL

INSTALLATION INSTRUCTIONS FOR OPTIONAL FG-3413 SILL RECEPTOR

INSTALL SILL RECEPTOR AND END DAM

NOTE: IF A TWO PIECE HEAD RECEPTOR IS NOT USED, A 1/4" MINIMUM CLEARANCE IS REQUIRED AT THE HEAD CONDITION TO ALLOW FRAME INSTALLATION.

ANCHOR SILL RECEPTOR WITHIN 4" FROM EITHER SIDE OF INTERMEDIATE MULLIONS. ANCHOR SIZE AND FREQUENCY SHOULD BE DETERMINED BY STRUCTURAL REQUIREMENTS. CAP SEAL FLASHING ANCHORS AS SHOWN.

DRILL 1/4" WEEP HOLES
LOCATE AT MID-LITE

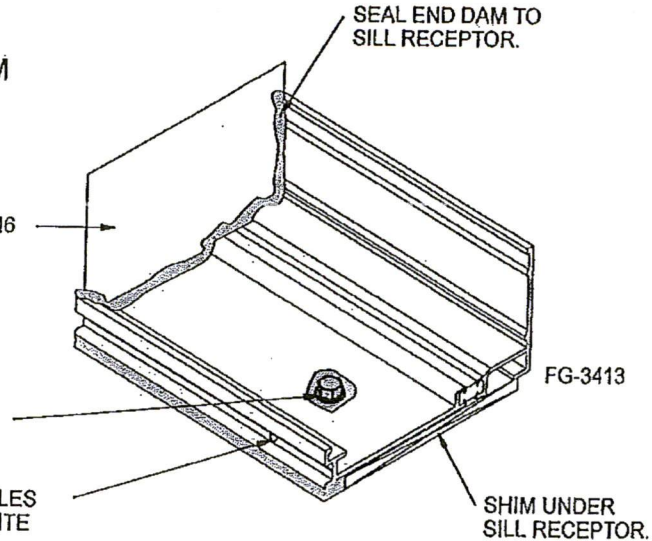

INSTALL SPLICE SLEEVE

NOTE: INSTALL SILL RECEPTOR LEVEL.

SEAL WITH A NON-SKINNING
NON-HARDENING SEALANT.
FILL BREAK IN FLASHING
AND UNDER SPLICE.

SEAL SILL RECEPTOR
VERTICAL SPLICE JOINT

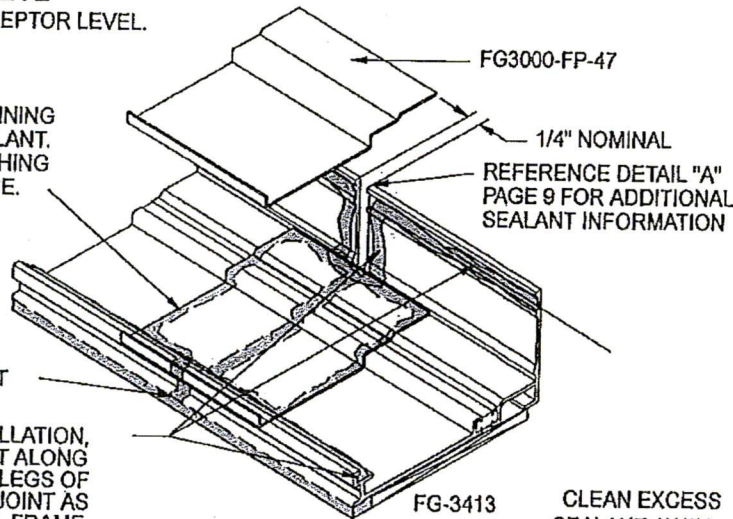

JUST PRIOR TO FRAME INSTALLATION,
APPLY CONTINUOUS SEALANT ALONG
GROOVE IN FRONT AND BACK LEGS OF
SILL RECEPTOR AND AROUND JOINT AS
SHOWN. IMMEDIATELY INSTALL FRAME
INTO SILL.

CLEAN EXCESS
SEALANT AWAY.

SET FRONT OF FRAME IN
SILL RECEPTOR AND TILT
BACK INTO PLACE.

INTERIOR PERIMETER SEAL
AT SILL IS OPTIONAL AND FOR
COSMETIC PURPOSES ONLY.

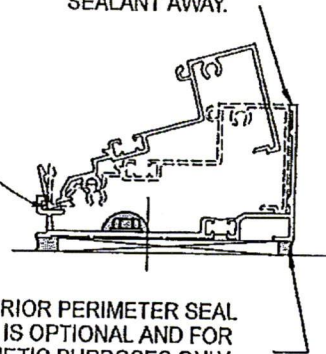

NOTE:

- 1) SILL RECEPTOR SHALL BE INSTALLED LEVEL AND SHOULD NEVER TILT TOWARDS INTERIOR OF BUILDING.
- 2) THE FG-3413 SILL RECEPTOR IS DESIGNED TO WITHSTAND A MAXIMUM END REACTION OF 600 LBS.
- 3) SPLICE SILL RECEPTOR AT MID-LITE.
- 4) LOCATE SPLICE JOINT AT DISTANCE OF NO MORE THAN EVERY 12 FEET.

2689 LIVINGSTON ROAD • JACKSON, MISSISSIPPI • 39213 • PHONE: 601.981.9611 • FAX: 601.981.9616

HOLLOW METAL & HARDWARE DIVISION

QUOTATION

CUSTOMER	<u>Tyler Construction</u>	DATE	<u>02-Apr-14</u>
	<u>Attn: Pete Willis</u>	PROJECT	<u>Madison County Courthouse</u>
		ADDRESS	<u>Canton, MS</u>
REQ. BY			
PHONE #		FAX#	

Credit for changing interior doors from Special-Lite AMP Doors to Graham wood prefinished doors to match existing doors.

Credit Total - \$10,578.00

Please advise if this change is approved. We will need an existing door sample to send to the manufacturer to have custom color samples done for approval.

Please see attached terms and conditions.

TERMS AND CONDITIONS Net 30 Days

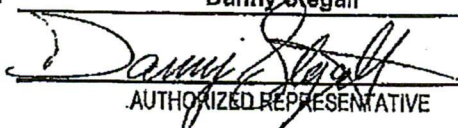
SUBMITTED BY	<u>Danny Stegall</u>	ACCEPTED BY	
SIGNATURE	 AUTHORIZED REPRESENTATIVE	SIGNATURE	
DATE	<u>4/3/2014</u>	DATE	



Madison County Buildings and Grounds

Mark Houston, County Administrator ▪ Danny Lee, Director of Buildings & Grounds

125 West North Street, Post Office Box 608, Canton, Mississippi 39046

Office 601-855-5500 ▪ Facsimile 601-855-5759

danny.lee@madison-co.com

June 13, 2014

Mr. Preston McKay, Project Manager
M3A Architects
4880 McWillie Circle
Jackson, Ms. 39206

RE: Circuit Courthouse Renovation
Approval of Changes and Additions

Dear Mr. Mckay,

Per our meeting with Tyler Construction on June 13, 2014, Madison County is approving the following changes and additions:

- A. Pricing for DA's Office: **Approved as noted**
 - a. Approval of line items 1 and 2 only.
- B. Pricing for revised Canopy Plan: **Approved**
- C. Flooring Additions: **Not Approved**
- D. Fire Riser Deduct: **Approved**
- E. Additional Painting: **Not Approved**
- F. Deduct for Mods to Access Control and Door Changes: **Approved**
- G. Deduct for changing Acrylic to Wood Doors: **Approved**
- H. Add for Extended General Conditions: **Approved as discussed**
- I. Add for moving conduit and wire: **Approved**

J. Add for fixing receptacles: **Approved**

Please contact me if there are any changes or additions that I need to address.

Sincerely,

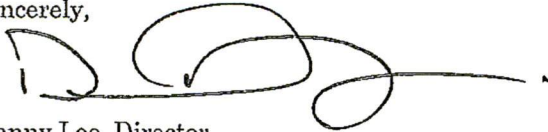
A handwritten signature in black ink, appearing to be 'Danny Lee', with a long horizontal line extending to the right.

Danny Lee, Director
Madison County Building and Grounds

CC: Mark Houston, Madison County Administrator



203 W. BEACON STREET
PHILADELPHIA, MS 39350
601.656.3200 (o)
601.656.3322 (f)
www.tylerconstruct.com

To: M3A Architecture
c/o Preston McKay
4880 McWilley
Jackson, Mississippi 39206

May 6, 2014

From: Tyler Construction Group
Pete Willis
203 W Beacon Street
Philadelphia, MS 39350

RE: Requested Pricing for COR#2 (all items requested to date)

Preston- Below is the pricing you requested.

A. Pricing for DA's Office and Room #221

The first 2 items are the only additional work to the DA's office that was not in the original scope. The remaining items are all for room #221.

1) 48 SF Carpet Demo @ DA's office (Labor)	\$560.00	accepted
2) 38 SF Wall Demo @ DA's office (Labor)	\$560.00	accepted
3) 80 LF 6" metal track (25ga, \$0.92/LF)	\$73.00	
4) 250 LF 6" metal stud (25ga, \$0.92/LF)	\$230.00	
5) 18 pc 4'x8'x5/8" type X sheetrock	\$184.00	
6) 240 SF 6" sound batt insulation	\$93.00	
7) 120 LF wall angle (\$0.58/LF)	\$69.00	
8) 84 LF main tee (\$0.92/LF)	\$77.00	
9) 72 LF 4' tees (\$0.86/LF)	\$61.00	
10) 102 LF 2' tee (\$0.86/LF)	\$87.00	
11) 248 SF 2x2 LAT #1722 Dune	\$466.00	
12) 42 LF 4" rubber base & labor	\$51.00	
13) 22 LF new wall (labor)	\$560.00	
14) 512 SF hang & finish sheetrock (labor)	\$2,240.00	
15) 1000 SF paint ceiling	\$1,120.00	
16) 243 SF hang ceiling (labor)	\$1,120.00	
17) Prime Contractor 15% O&P	\$1,133.00	
18) Electric & Data	\$5,500.00	
19) HVAC	\$1,935.00	
20) 10% O&P on Subcontractors	\$743.00	
21) Total	\$16,862.00	

Additional Time requested – 21 days

B. Pricing for Revised Canopy Plan

1. Deduct 18cy 4000PSI	\$1,440.00
2. Deduct 50LF Saw cut	\$150.00
3. Deduct 900 8x8x16	\$3,291.00
4. Deduct 29 Bags Mortar	\$240.00
5. Deduct 4cy Sand	\$128.00
6. Deduct 500 LF8" Block Wire	\$170.00
7. Deduct 3cy Grout Fill	\$225.00
8. Deduct @ 175 razor tape	\$1,798.00
9. Deduct electric heater	\$478.00
10. Add 5cy 4000 PSI Concrete	\$550.00
11. Add 6" Track 143LF	\$551.00
12. Add 6" Metal Stud 110LF	\$434.00
13. Add Un-Faced Insulation 475sf	\$648.00
14. Add demo 50lf Curb	\$800.00
15. Add for Roofing	\$3,760.00
16. Add for New Roll up Door	\$16,523.00
17. O&P	\$1,762.00
18. Total	\$17,108.00

Additional Time requested – 21 days

C. Flooring Additions per M3A (two requests)

1. Add per Sub-K Quote- First request 3/21/14	\$62,100.00
2. Add per Sub-K Quote- Second request 4/22/14	\$24,500.00
3. O&P	\$8,660.00
4. Total	\$95,260.00

Additional Time requested – 21 days

D. Fire Riser Deduct

1. Complete Deduct	\$6,900.00
2. Total	\$6,900.00

E. Additional Painting

1. Add for additional Painting	\$24,563.00
2. O&P	\$2,456.00
3. Total	\$27,019.00

Additional Time requested – 14 days

F. Deduct for Mods to Access Control and Door Changes (per new schedule)

1. Deduct per Sub-K Quote	\$10,340.00
2. Total	\$10,340.00

Additional Time requested – 21 days

G. Deduct for changing Acrylic to Wood Doors

1. <u>Deduct per Sub-K Quote</u>	\$10,578.00
2. Total	\$10,578.00

H. Add for Extended General Conditions

1. Additional Supervision	\$21,000.00
2. Additional Project Management	\$14,000.00
3. Additional Storage	\$1,900.00
4. <u>O&P</u>	<u>\$5,535.00</u>
5. Total	\$42,435.00

I. Add for Moving Conduit and Wire Around New Door Openings and Troubleshooting Receptacles that lost Power due to Lightning Strike.

1. Labor Hours (57 hours x \$54/hr)	\$3078.00
2. Material	\$463.00
3. <u>O&P</u>	<u>\$531.00</u>
4. Total	\$4072.00

J. Add for Fixing the Receptacles damaged by the Lightning Strike

1. Labor and materials	\$2500.00
2. <u>O&P</u>	<u>\$375.00</u>
3. Total	\$2875.00

Pete Willis
Tyler Construction Group
601-656-3200
pwillis@tylerconstruct.com

Application and Certificate for Payment

TO OWNER: Madison County Board of Supervisors 146 West Center Street Canton, Mississippi 39046	PROJECT: Madison County Circuit Courthouse Renovation Canton, Mississippi	APPLICATION NO: 007- Final	Distribution to:
FROM CONTRACTOR: Tyler Construction Group 203 W Beacon Philadelphia Mississippi 39350	VIA ARCHITECT: M3A Architecture, PLLC 4880 McWillie Circle Jackson, Mississippi 39206	PERIOD TO: January 05, 2015	OWNER: X
		CONTRACT FOR: General Construction	ARCHITECT: X
		CONTRACT DATE: January 09, 2014	CONTRACTOR:
		PROJECT NOS: 10-018 / 2014-131 /	FIELD:
			OTHER:

CONTRACTOR'S APPLICATION FOR PAYMENT

Application is made for payment, as shown below, in connection with the Contract. Continuation Sheet, AIA Document G703, is attached.

1. ORIGINAL CONTRACT SUM	\$	800,000.00
2. NET CHANGE BY CHANGE ORDERS	\$	0.00
3. CONTRACT SUM TO DATE (Line 1 ± 2)	\$	800,000.00
4. TOTAL COMPLETED & STORED TO DATE (Column G on G703)	\$	800,000.00
5. RETAINAGE:		
a. 0 % of Completed Work (Column D + E on G703)	\$	0.00
b. 0 % of Stored Material (Column F on G703)	\$	0.00
Total Retainage (Lines 5a + 5b or Total in Column I of G703)	\$	0.00
6. TOTAL EARNED LESS RETAINAGE	\$	800,000.00
(Line 4 Less Line 5 Total)		
7. LESS PREVIOUS CERTIFICATES FOR PAYMENT	\$	655,730.00
(Line 6 from prior Certificate)		
8. CURRENT PAYMENT DUE	\$	144,270.00
9. BALANCE TO FINISH, INCLUDING RETAINAGE (Line 3 less Line 6)	\$	0.00

CHANGE ORDER SUMMARY	ADDITIONS	DEDUCTIONS
Total changes approved in previous months by Owner	\$ 0.00	\$ 0.00
Total approved this Month	\$ 0.00	\$ 0.00
TOTALS	\$ 0.00	\$ 0.00
NET CHANGES by Change Order	\$	0.00

The undersigned Contractor certifies that to the best of the Contractor's knowledge, information and belief the Work covered by this Application for Payment has been completed in accordance with the Contract Documents, that all amounts have been paid by the Contractor for Work for which previous Certificates for Payment were issued and payments received from the Owner, and that current payment shown herein is now due.

CONTRACTOR:
By: [Signature]
State of: Mississippi
County of: Washoba
Subscribed and sworn to before
me this 5 day of January 2015
Notary Public: Bonnie S. Bryan
My Commission expires: August 20, 2018



ARCHITECT'S CERTIFICATE FOR PAYMENT

In accordance with the Contract Documents, based on on-site observations and the data comprising this application, the Architect certifies to the Owner that to the best of the Architect's knowledge, information and belief the Work has progressed as indicated, the quality of the Work is in accordance with the Contract Documents, and the Contractor is entitled to payment of the AMOUNT CERTIFIED.

AMOUNT CERTIFIED \$ 144,270.00
(Attach explanation if amount certified differs from the amount applied. Initial all figures on this Application and on the Continuation Sheet that are changed to conform with the amount certified.)

ARCHITECT:
By: [Signature] Date: 4/9/15

This Certificate is not negotiable. The AMOUNT CERTIFIED is payable only to the Contractor named herein. Issuance, payment and acceptance of payment are without prejudice to any rights of the Owner or Contractor under this Contract.

[Signature] 4/29/2015



AIA Document G703™ – 1992

Continuation Sheet

AIA Document, G702™–1992, Application and Certification for Payment, or G736™–2009, Project Application and Project Certificate for Payment, Construction Manager as Adviser Edition, containing Contractor's signed certification is attached.

In tabulations below, amounts are in US dollars.

Use Column I on Contracts where variable retainage for line items may apply.

APPLICATION NO: 007

APPLICATION DATE: 01/05/2015

PERIOD TO: 01/05/2015

ARCHITECT'S PROJECT NO: 10-018

ITEM NO.	DESCRIPTION OF WORK	SCHEDULED VALUE	WORK COMPLETED		MATERIALS PRESENTLY STORED (NOT IN D OR E)	TOTAL COMPLETED AND STORED TO DATE (D+E+F)		BALANCE TO FINISH (C - G)	RETAINAGE (IF VARIABLE RATE)
			FROM PREVIOUS APPLICATION (D + E)	THIS PERIOD		(G ÷ C)	(D+E+F)		
1040	Site Supervision On Site	34,800.00	32,680.00	2,120.00	0.00	34,800.00	100.00 %	0.00	0.00
1130	Audio Equipment Allowance	5,000.00	5,000.00	0.00	0.00	5,000.00	100.00 %	0.00	0.00
1150	Execute and Submit Contracts Bonds	18,400.00	18,400.00	0.00	0.00	18,400.00	100.00 %	0.00	0.00
1151	Execute and Submit Contract Insurance	5,789.00	5,789.00	0.00	0.00	5,789.00	100.00 %	0.00	0.00
1180	Mobilization	30,000.00	30,000.00	0.00	0.00	30,000.00	100.00 %	0.00	0.00
2200	Demo Interior Floors	3,500.00	3,500.00	0.00	0.00	3,500.00	100.00 %	0.00	0.00
2210	Demo Ceilings	15,000.00	15,000.00	0.00	0.00	15,000.00	100.00 %	0.00	0.00
2220	Demo Walls	11,200.00	11,200.00	0.00	0.00	11,200.00	100.00 %	0.00	0.00
2230	Demo Duct Work	4,900.00	4,900.00	0.00	0.00	4,900.00	100.00 %	0.00	0.00
2250	Demo for Roll-Up Door	1,050.00	1,050.00	0.00	0.00	1,050.00	100.00 %	0.00	0.00
2260	Demo Exterior Trees	7,200.00	7,200.00	0.00	0.00	7,200.00	100.00 %	0.00	0.00
2270	Install Fench Drain System	23,276.00	23,276.00	0.00	0.00	23,276.00	100.00 %	0.00	0.00
2280	Demo Washed Gravel Concrete	3,500.00	3,500.00	0.00	0.00	3,500.00	100.00 %	0.00	0.00
2290	Place New Washed Gravel Concrete	6,550.00	6,550.00	0.00	0.00	6,550.00	100.00 %	0.00	0.00
3300	Excavate and Pour Grade Beams	5,700.00	5,700.00	0.00	0.00	5,700.00	100.00 %	0.00	0.00
3310	Lay New Block Wall	29,088.00	29,088.00	0.00	0.00	29,088.00	100.00 %	0.00	0.00

AIA Document G703™ – 1992. Copyright © 1963, 1965, 1966, 1967, 1970, 1978, 1983 and 1992 by The American Institute of Architects. All rights reserved. **WARNING: This AIA® Document is protected by U.S. Copyright Law and International Treaties. Unauthorized reproduction or distribution of this AIA® Document, or any portion of it, may result in severe civil and criminal penalties, and will be prosecuted to the maximum extent possible under the law.** This document was produced by AIA software at 13:53:35 on 01/06/2015 under Order No.7817920091_1 which expires on 09/03/2015, and is not for resale.

User Notes:

(2000120889)

A ITEM NO.	B DESCRIPTION OF WORK	C SCHEDULED VALUE	D WORK COMPLETED		F MATERIALS PRESENTLY STORED (NOT IN D OR E)	G TOTAL COMPLETED AND STORED TO DATE (D+E+F)		H BALANCE TO FINISH (C - G)	I RETAINAGE (IF VARIABLE RATE)
			FROM PREVIOUS APPLICATION (D + E)	THIS PERIOD		% (G ÷ C)			
	(exterior)								
4000	Lay Up Interior Block Walls	9,050.00	9,050.00	0.00	0.00	9,050.00	100.00 %	0.00	0.00
4400	Demo Concrete at Sally Port	6,800.00	6,800.00	0.00	0.00	6,800.00	100.00 %	0.00	0.00
5240	Erect Metal Canopy @ Salley Port	16,100.00	16,100.00	0.00	0.00	16,100.00	100.00 %	0.00	0.00
6600	Install/Alter Millwork	9,000.00	9,000.00	0.00	0.00	9,000.00	100.00 %	0.00	0.00
8555	Install Roll Up Door	3,200.00	3,200.00	0.00	0.00	3,200.00	100.00 %	0.00	0.00
8800	Install New Door/Frames	53,000.00	0.00	53,000.00	0.00	53,000.00	100.00 %	0.00	0.00
8810	Install new Doors	3,300.00	0.00	3,300.00	0.00	3,300.00	100.00 %	0.00	0.00
8820	Install Access Controls	54,000.00	0.00	54,000.00	0.00	54,000.00	100.00 %	0.00	0.00
8830	ReRubber All Windows	16,000.00	16,000.00	0.00	0.00	16,000.00	100.00 %	0.00	0.00
8840	Re-Caulk All Windows	5,600.00	5,600.00	0.00	0.00	5,600.00	100.00 %	0.00	0.00
8850	Insert new Storefront Doors	6,400.00	0.00	6,400.00	0.00	6,400.00	100.00 %	0.00	0.00
8860	Install Detention Hrdw/Glazing/Cell Doors	32,800.00	32,800.00	0.00	0.00	32,800.00	100.00 %	0.00	0.00
9910	Paint New Walls and Frames	22,000.00	22,000.00	0.00	0.00	22,000.00	100.00 %	0.00	0.00
9920	Install Ceiling Grid	6,744.00	6,744.00	0.00	0.00	6,744.00	100.00 %	0.00	0.00
9930	Install Ceiling Tiles	12,679.00	12,679.00	0.00	0.00	12,679.00	100.00 %	0.00	0.00
9940	Install Flooring/Rubber Base	17,574.00	17,574.00	0.00	0.00	17,574.00	100.00 %	0.00	0.00

ITEM NO.	DESCRIPTION OF WORK	SCHEDULED VALUE	WORK COMPLETED		MATERIALS PRESENTLY STORED (NOT IN D OR E)	TOTAL COMPLETED AND STORED TO DATE (D+E+F)		BALANCE TO FINISH (C - G)	RETAINAGE (IF VARIABLE RATE)
			FROM PREVIOUS APPLICATION (D + E)	THIS PERIOD		% (G ÷ C)			
9950	Strip & Wax Floors	1,100.00	1,100.00	0.00	0.00	1,100.00	100.00 %	0.00	0.00
9960	Metal Stud Framing	3,500.00	3,500.00	0.00	0.00	3,500.00	100.00 %	0.00	0.00
9970	Hang Sheet Rock	4,800.00	4,800.00	0.00	0.00	4,800.00	100.00 %	0.00	0.00
9980	Finish Sheet Rock	4,100.00	4,100.00	0.00	0.00	4,100.00	100.00 %	0.00	0.00
9990	Paint Exsiting Walls Frames	12,500.00	12,500.00	0.00	0.00	12,500.00	100.00 %	0.00	0.00
10459	Exterior Canopy	6,500.00	6,500.00	0.00	0.00	6,500.00	100.00 %	0.00	0.00
15000	Plumbing / Rough In	6,700.00	6,700.00	0.00	0.00	6,700.00	100.00 %	0.00	0.00
15010	Mechanical Rough-In (Duct Work)	13,000.00	13,000.00	0.00	0.00	13,000.00	100.00 %	0.00	0.00
15020	Set Units	5,600.00	5,600.00	0.00	0.00	5,600.00	100.00 %	0.00	0.00
15040	Set Diffusers	2,100.00	2,100.00	0.00	0.00	2,100.00	100.00 %	0.00	0.00
15060	Install plumbing Fixtures	6,000.00	6,000.00	0.00	0.00	6,000.00	100.00 %	0.00	0.00
15070	Install Site Fire Main	6,900.00	6,900.00	0.00	0.00	6,900.00	100.00 %	0.00	0.00
16020	Run Interior Conduit	18,600.00	18,600.00	0.00	0.00	18,600.00	100.00 %	0.00	0.00
16030	Pull Wire	27,200.00	27,200.00	0.00	0.00	27,200.00	100.00 %	0.00	0.00
16050	Install Lights	24,000.00	24,000.00	0.00	0.00	24,000.00	100.00 %	0.00	0.00
16060	Power Up & Trim Out	10,000.00	10,000.00	0.00	0.00	10,000.00	100.00 %	0.00	0.00
16070	Plugs/Switches	14,600.00	14,600.00	0.00	0.00	14,600.00	100.00 %	0.00	0.00
16080	Connect to Panel	5,600.00	5,600.00	0.00	0.00	5,600.00	100.00 %	0.00	0.00
CO1	Add concrete work and Fixing Glass	0.00	0.00	0.00	0.00	0.00	0.00 %	0.00	0.00
CO2	Misc Adds	0.00	0.00	0.00	0.00	0.00	0.00 %	0.00	0.00
17010	Sales tax	28,000.00	23,150.00	4,850.00	0.00	28,000.00	100.00 %	0.00	0.00
17020	Overhead	60,000.00	49,700.00	10,300.00	0.00	60,000.00	100.00 %	0.00	0.00
17030	Profit	60,000.00	49,700.00	10,300.00	0.00	60,000.00	100.00 %	0.00	0.00
17031	Credit for Unused	0.00	0.00	0.00	0.00	0.00	0.00 %	0.00	0.00

A	B	C	D	E	F	G		H	I
ITEM NO.	DESCRIPTION OF WORK	SCHEDULED VALUE	WORK COMPLETED		MATERIALS PRESENTLY STORED (NOT IN D OR E)	TOTAL COMPLETED AND STORED TO DATE (D+E+F)	% (G ÷ C)	BALANCE TO FINISH (C - G)	RETAINAGE (IF VARIABLE RATE)
			FROM PREVIOUS APPLICATION (D + E)	THIS PERIOD					
	Allowance								
	GRAND TOTAL	\$800,000.00	\$655,730.00	\$144,270.00	\$0.00	\$800,000.00	100.00 %	\$0.00	\$0.00